

# Pompe portable à moteur thermique

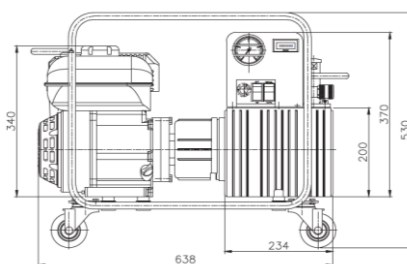
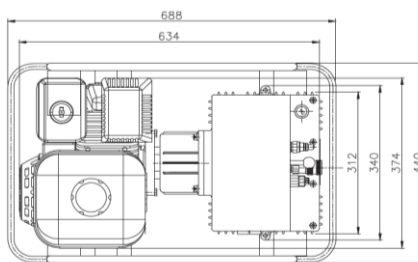
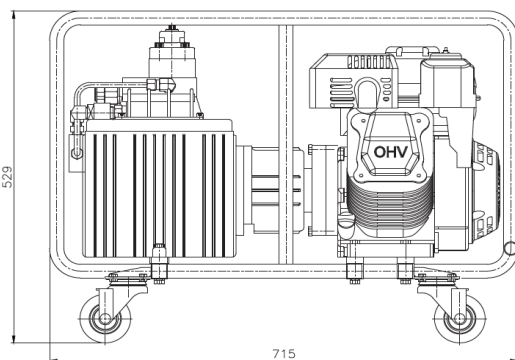
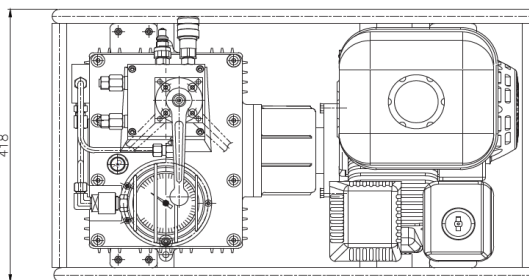
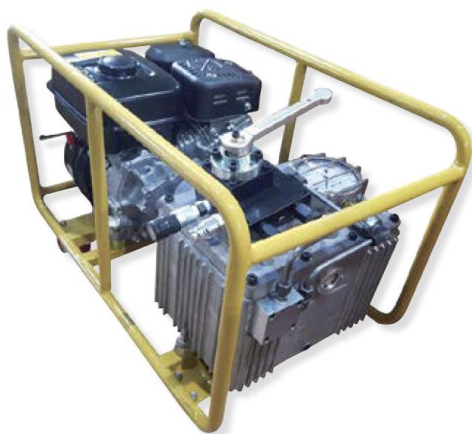
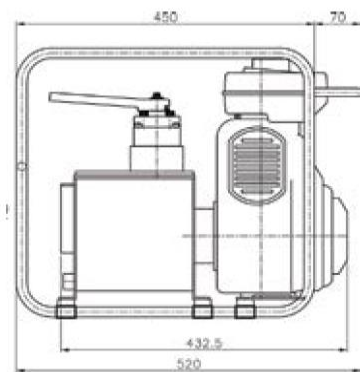
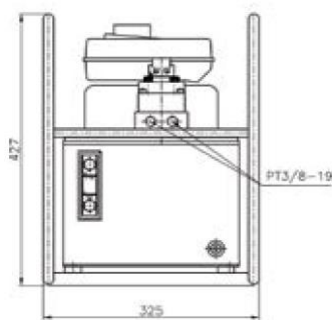

Modèle	Capacité d'huile	Pression (bar)		Débit (l/min)		Poids	Type
		Haut	Bas	Haut	Bas		
TEP2-M	8l			1,15	4,3	32kg	Commande manuelle

TEP5-M	11l	700	70	1,37	4,3	60kg	Commande manuelle
TEP5-2S	11l			1,37	4,3	60kg	Electrovanne